

CHIP RESISTOR

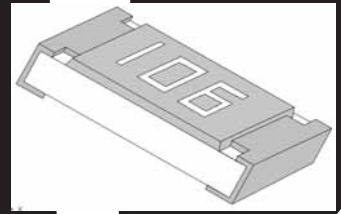

Chip Resistor
Voltage
器、汽
Battery, Power supply, CD-R

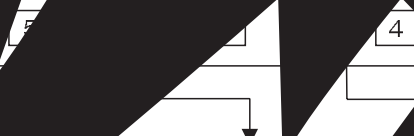

電阻溫度系數

型號 Type	代號 Code
03	0603
05	0805
06	1206
1210	1210
1812	1812
10	2010
12	2512

包裝方式代號

Packing Style Code

裝方法

T	編帶包裝 Tape & Reel
C	塑料袋散裝 Case

電阻值誤差精度代號

Resistance Tolerance Code

代號 Code	誤差精度 Tolerance
F	± 1%
J	± 5%

高壓
Thick
電阻器
Voltage
Resistors

個數

• 結構及規格尺寸 CONSTRUCTION AND DIMENSION

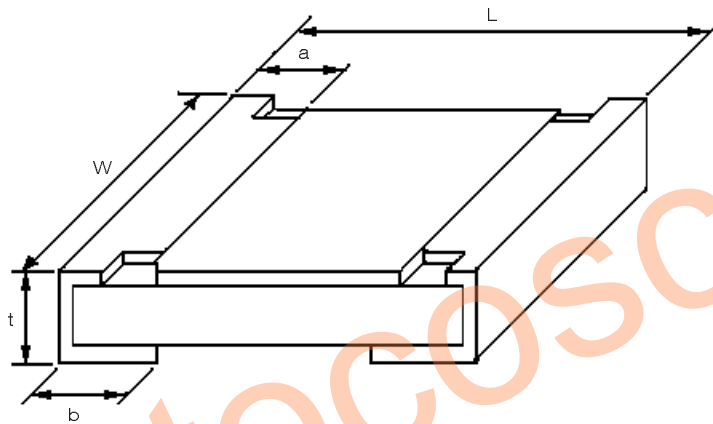
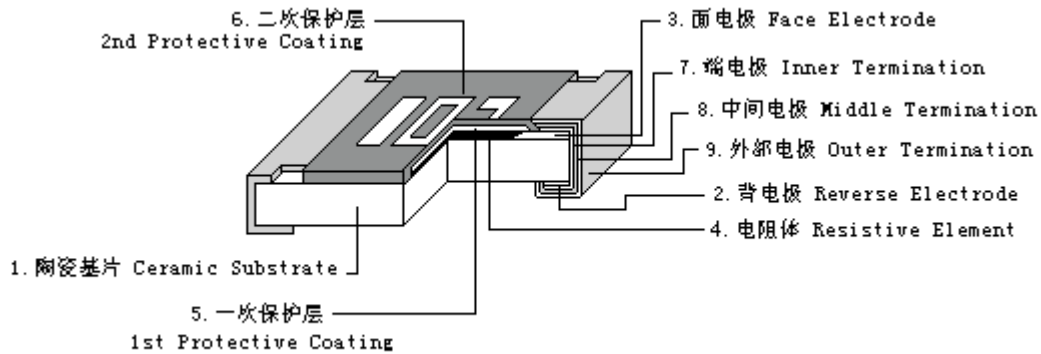

單位unit:mm

型號 TYPE	L	W	t	a	b
0603	1.60±0.15	0.80±0.15	0.40±0.10	0.30±0.20	0.30±0.20
0805	2.00±0.20	1.25±0.15	0.50±0.10	0.30±0.20	0.40±0.20
1206	3.20±0.20	1.60±0.15	0.55±0.10	0.50±0.20	0.50±0.20
1210	3.20±0.20	2.50±0.20	0.55±0.10	0.50±0.20	0.50±0.20
1218	3.15±0.15	4.60±0.20	0.55±0.10	0.37±0.20	0.65±0.20
1812	4.50±0.20	3.20±0.20	0.55±0.10	0.50±0.20	0.50±0.20
2010	5.00±0.20	2.50±0.20	0.55±0.10	0.60±0.20	0.60±0.20
2512	6.40±0.20	3.20±0.20	0.55±0.10	0.60±0.20	0.60±0.20

- 產品外觀 APPEARANCE

基本要求 Basic requirement
1. 電阻器表面保護膜覆蓋完好且難以脫落,表面平整。 2. 電阻器引出端電極覆蓋均勻、鍍層較難脫落,且平整、無裂痕、針孔、變色。 3. 電阻器芯片無裂痕、標志可辨。 1. The surface of resistor is covered with Protective Coating which hard to fade, and the surface of coating should avoid unevenness. 2. The terminal part is covered equable, the plating is hard to fade, and should avoid unevenness,flaw, pinhole and discoloration. 3. With a clear mark, the resistor body is crack-free.

- 參考標準 REFERENCE STANDARD

GB/T 5729-2003
GB/T 9546-1995

- 負荷下降曲綫 DERATING CURVE

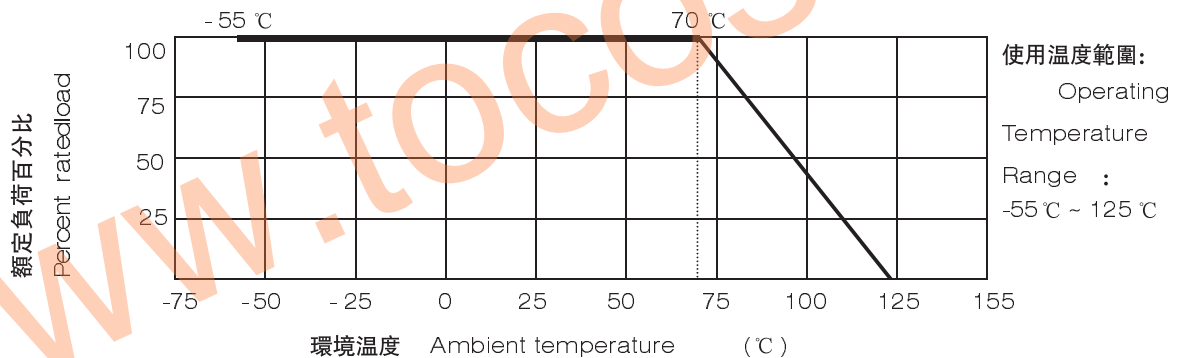

當電阻使用的環境溫度超過70°C時,其額定負荷(額定功率或額定電流)按上述曲綫下降。

For resistors operated in ambient over 70°C, rated load (power rating or current rating) shall be derated in accordance with the above figure.

• 額定值 RATINGS

項目 Item	0603	0805	1206	1210	1812	2010	2512
額定功率 Power Rating	1/10W	1/8W	1/4W	1/3W	1/2W	3/4W	1W
最大工作電壓(V) Max.Working Voltage	300	400	500	600	700	800	1000
最大過負荷電壓(V) Max.Overload Voltage	600	800	1000	1200	1400	1600	2000
電阻溫度係數 Resistance Temperature Coefficient	20K Ω < R \leq 10M Ω : \pm 250ppm/ $^{\circ}$ C 10M Ω < R \leq 100M Ω : \pm 500ppm/ $^{\circ}$ C						
阻值範圍 Resistance Range	20K Ω ~ 100M Ω E-24系列						
阻值誤差精度 Resistance Tolerance	\pm 1% \pm 2% \pm 5% \pm 10%						
使用溫度範圍 Operating Temperature Range	-55 $^{\circ}$ C ~ +125 $^{\circ}$ C						
額定溫度 Rated Temperature	+70 $^{\circ}$ C						

注：額定電壓 = $\sqrt{\text{額定功率} \times \text{標稱電阻值}}$ 或最大工作電壓兩者中的較小值。

Note: Rated Voltage = $\sqrt{\text{Power Rating} \times \text{Resistance Value}}$ or Max. Working Voltage, whichever is lower.

• 特性 CHARACTERISTICS

項目 Item	標準 Specifications	測試方法 (GB/T 5729-2003) Test Methods (GB/T 5729-2003)
端頭強度 Bending Strength	無可見損傷 No mechanical damage $\Delta R \leq \pm (1.0\%R + 0.05\Omega)$	彎曲速度 (Speed) : 1 mm/s 彎曲距離 (Bending Distance) : 3mm (0603, 0805, 1206), 2mm (1210, 1812, 2010, 2512)
電阻溫度係數 T.C.R	在規定值內 within specified T.C.R	-55 $^{\circ}$ C ~ +125 $^{\circ}$ C
溫度循環 Temperature Cycling	無可見損傷 No mechanical damage $\Delta R \leq \pm (1.0\%R + 0.05\Omega)$	-55 $^{\circ}$ C (30分鐘) ~ 常溫 (5分鐘) ~ 125 $^{\circ}$ C (30分鐘) 5個循環 -55 $^{\circ}$ C (30min) ~ normal temperature (5min) ~ 125 $^{\circ}$ C (30min) 5 cycles
短時間過負載 Short Time Overload	無可見損傷 No mechanical damage $\Delta R \leq \pm (5.0\%R + 0.05\Omega)$	2.5倍額定電壓或最大過負荷電壓 (取最小者) 保持5秒 2.5 \times Rated voltage or Max. Overload Voltage whichever is lower for 5 seconds
耐焊接熱 Resistance to Soldering Heat	無可見損傷 No mechanical damage $\Delta R \leq \pm (1.0\%R + 0.05\Omega)$	270 $^{\circ}$ C \pm 5 $^{\circ}$ C 10 \pm 1秒 270 $^{\circ}$ C \pm 5 $^{\circ}$ C 10s \pm 1s

厚膜片式高壓電阻器

THICK FILM HIGH-VOLTAGE CHIP RESISTORS

續上表

項目 Item	標準 Specifications	測試方法 (GB/T 5729-2003) Test Methods (GB/T 5729-2003)
穩態濕熱 Steady state humidity	無可見損傷 No mechanical damage $\Delta R \leq \pm (3.0\%R + 0.1\Omega)$	40°C ± 2°C 90%~95%RH 1000小時 40°C ± 2°C 90%~95%RH 1000h
70°C 耐久性 Load Life	無可見損傷 No mechanical damage $\Delta R \leq \pm (3.0\%R + 0.1\Omega)$	70°C ± 2°C, 1000小時, 額定電壓通1.5小時/斷0.5小時 70°C ± 2°C, 1000h, Rated voltage 1.5h on/0.5h off
上限類別溫度耐久性 Endurance at upper temperature	無可見損傷 No mechanical damage $\Delta R \leq \pm (3.0\%R + 0.1\Omega)$	125°C ± 2°C 1000小時 125°C ± 2°C 1000h
耐溶劑性 Resistance to Solvent	無可見損傷 No mechanical damage $\Delta R \leq \pm (1.0\%R + 0.05\Omega)$	浸入三氯乙烯 10h ± 1小時 Dip in chloroethylene for 10h ± 1h.
絕緣電阻 Insulation Resistance	1000MΩ Min	在電極與基片間施加100V直流電壓, 保持1分鐘, 然後測絕緣電阻值。 Apply DC 100V between substrate and termination for 1 minute, then check insulation resistance.
可焊性 Solderability	可焊面積 ≥ 95% 95% Cover Min	240°C ± 5°C 2 ± 0.5秒 240°C ± 5°C 2s ± 0.5s
附着力 Adhesion	外觀無可見損傷 No mechanical damage	施加力5N 10s ± 1秒 Applying 5N 10s ± 1s

• 包裝 PACKAGING

- * 編帶包裝 Tape and reel
- 紙帶編帶 Paper taping
- 0603、0805、1206、1210

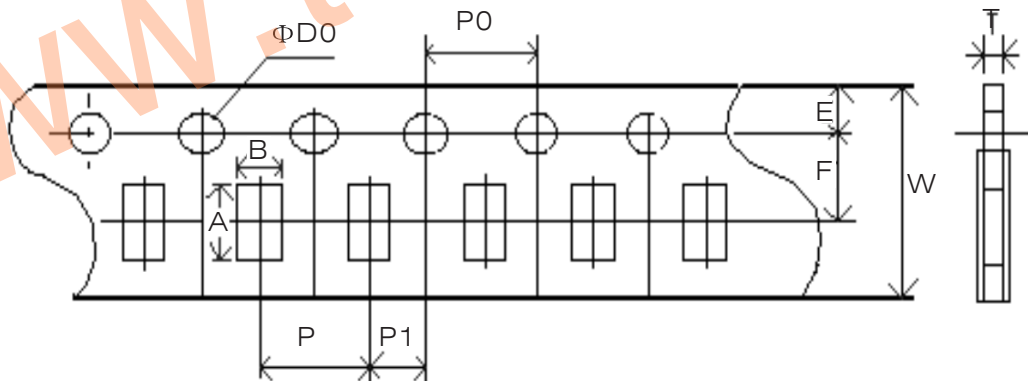

單位unit:mm

型號 TYPE	A	B	W	F	E
0603	1.85±0.1	1.10±0.1	8.0±0.20	3.5±0.05	1.75±0.1
0805	2.35±0.1	1.65±0.1	8.0±0.20	3.5±0.05	1.75±0.1
1206	3.50±0.2	1.90±0.2	8.0±0.20	3.5±0.05	1.75±0.1
1210	3.50±0.2	2.80±0.2	8.0±0.20	3.5±0.05	1.75±0.1

型號 TYPE	P	P0	P1	ΦD0	T
0603	4.0±0.1	4.0±0.1	2.0±0.05	1.5±0.1	0.60±0.1
0805	4.0±0.1	4.0±0.1	2.0±0.05	1.5±0.1	0.75±0.1
1206	4.0±0.1	4.0±0.1	2.0±0.05	1.5±0.1	0.75±0.1
1210	4.0±0.1	4.0±0.1	2.0±0.05	1.5±0.1	0.75±0.1

* 塑料帶編帶 Embossed tapping
1812、2010、2512:

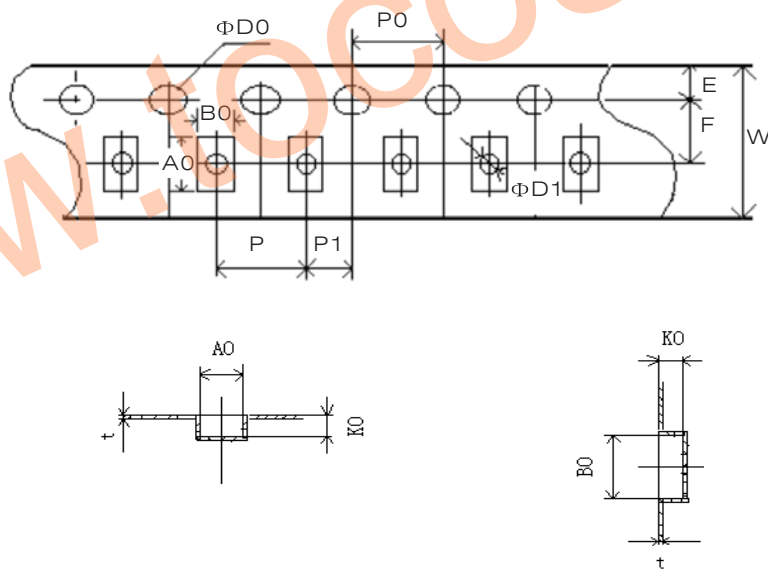

單位unit:mm

型號 TYPE	A0	B0	W	F	E	t
1812	4.80±0.10	3.40±0.10	12.00±0.10	5.50±0.10	1.75±0.10	0.25±0.05
2010	5.45±0.10	2.77±0.10	12.00±0.10	5.50±0.10	1.75±0.10	0.25±0.05
2512	6.73±0.10	3.40±0.10	12.00±0.10	5.50±0.10	1.75±0.10	0.25±0.05

厚膜片式高壓電阻器

THICK FILM HIGH-VOLTAGE CHIP RESISTORS

單位unit:mm

型號 TYPE	P	P0	P1	ΦD0	ΦD1	K0
1812	4.00±0.10	4.00±0.10	2.00±0.05	1.55±0.10	1.50±0.10	0.81±0.05
2010	4.00±0.10	4.00±0.10	2.00±0.05	1.50+0.10/-0	1.50±0.10	0.84±0.10
2512	4.00±0.10	4.00±0.10	2.00±0.05	1.50+0.10/-0	1.50±0.10	0.81±0.10

* 卷盤 Reel

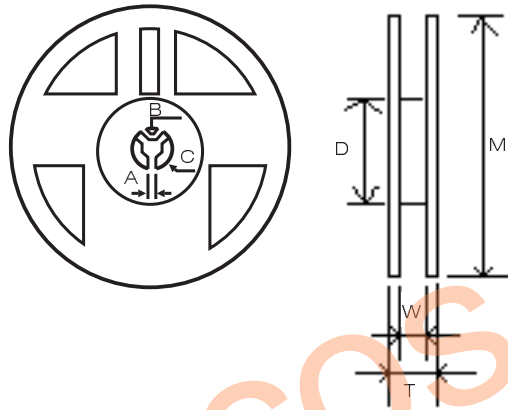

單位unit:mm

型號 TYPE	M	W	T	A	B	C	D
0603							
0805	178	9.5	12.5	2.0	13.0	21.0	80.0
1206	±2.0	±1.0	±1.5	±0.5	±0.5	±0.5	±2.0
1210							
1812	178	13.0	15.5	2.0	13.0	21.0	57.0
2010	±2.0	±0.5	±1.5	±0.5	±0.5	±0.5	±2.0
2512							

* 塑料盒包裝 Bulk case

單位unit:mm

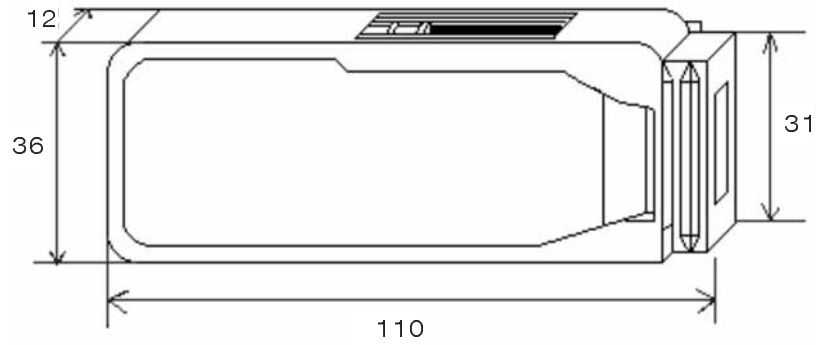

• 包裝數量 PACKAGING QUANTITY

包裝方法 Packaging style	編帶 Tape and reel		塑料盒 Bulk case					塑料袋散裝 Bulk	
	型號 Type	數量 (PCS) Quantity	0603	0805	1206	1210 2010	1812 2512	0603 0805 1206	1210 1812 2010 2512
數量 (PCS) Quantity	5000	4000	25000	10000	5000	1500	1000	≤10000	≤4000